

# SuperKlean

Environmentally Exceptional Washdown Products

## Duramix 8000GM Series Steam & Cold Water Mixing Station (8000GM-B, 8000GM-B-T, 8000GM-S, 8000GM-S-T)

### Features:

- **Best Design** - Operates with as little as 30 PSI for water and steam pressure, all the way up to 150 PSI without the need to change internal components, unlike some competitors.
- Dual output design with Secondary Outlet for a secondary hose or piping elsewhere.
- **Safety First** - Automatic shutoff feature built into the design to prevent live steam from passing through the unit. **Plant Safety Managers worldwide rate SuperKlean's DuraMix the safest steam unit available!**
- **Convenience** - Comes with everything necessary for immediate installation and connection to pipelines.
- **Simple Maintenance** - Only takes 15 minutes to complete preventive maintenance.
- **Industry's Longest Warranty — 3 years!**

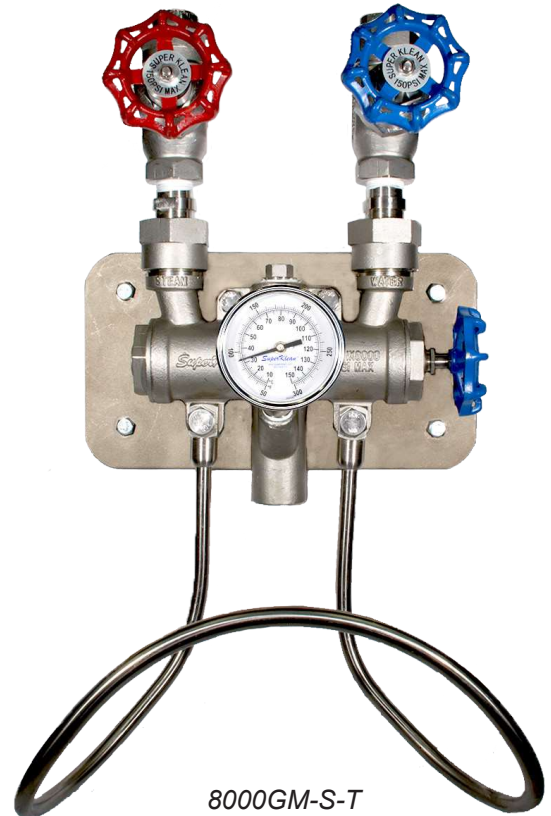

8000GM-S-T

	8000GM-B, 8000GM-B-T	8000GM-S, 8000GM-S-T
Inlet/Outlet Diameter:	¾" NPT	¾" NPT
Globe Valves:	Bronze	304 Stainless Steel
Mixer Body:	Bronze	304 Stainless Steel
Check Valves:	Bronze / Stainless Steel	304 Stainless Steel
Hose Rack:	304 Stainless Steel	304 Stainless Steel
Temperature Gauge (Optional):	Stainless Steel	Stainless Steel
Weight:	24.3 lbs. (11 kg)	26.5 lbs. (12 kg)
<b>Recommended Operative Conditions</b>		
Working Steam Pressure (Saturated Only):	30-150 PSI	30-150 PSI
Working Water Pressure:	30-150 PSI	30-150 PSI
Maximum Temperature:	200 °F (93 °C)	200 °F (93 °C)
Maximum Pressure:	150 PSI	150 PSI

(If steam to water ratio is more than 2:1, please refer to page 3)

# SuperKlean

Environmentally Exceptional Washdown Products

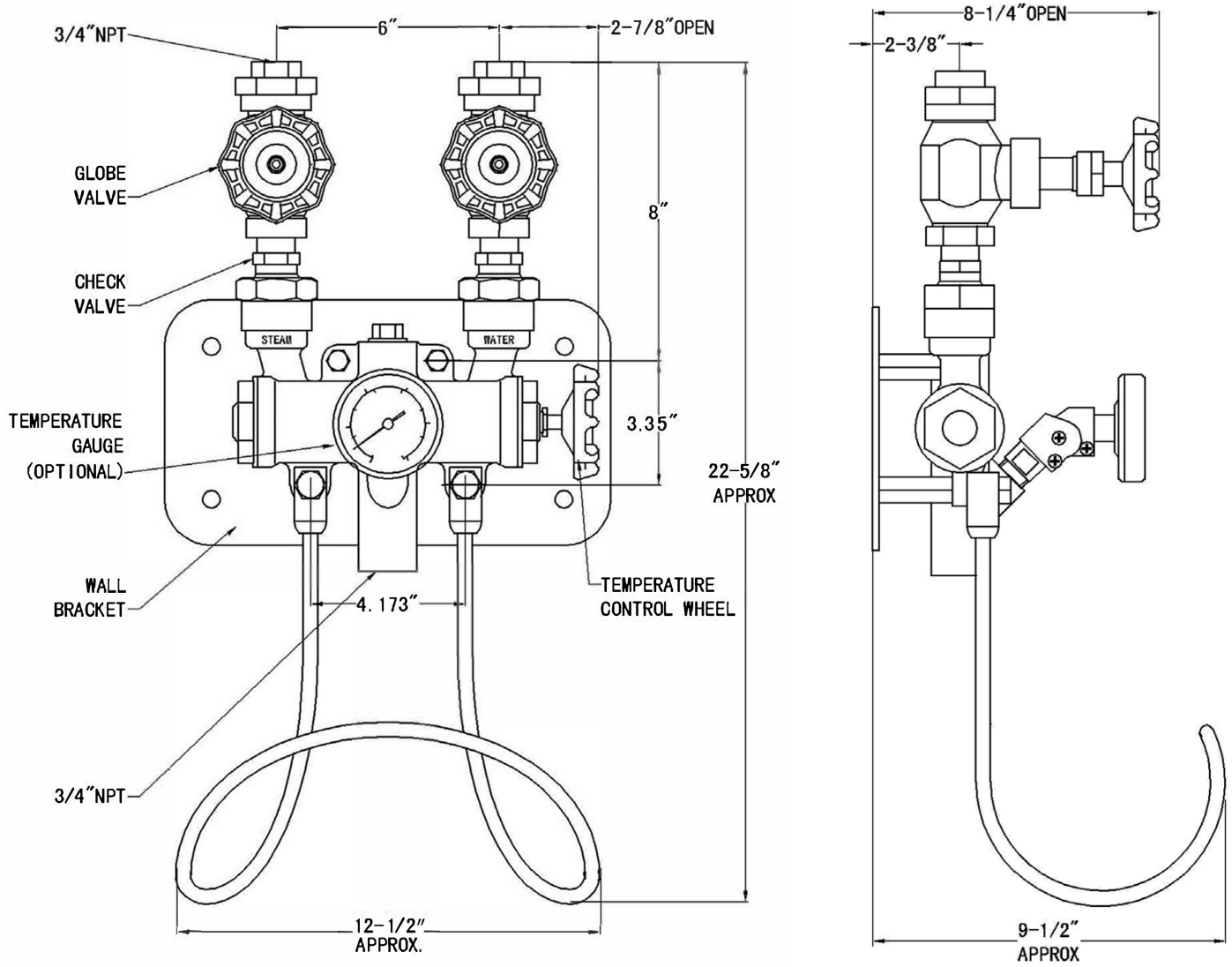

# SuperKlean

Environmentally Exceptional Washdown Products

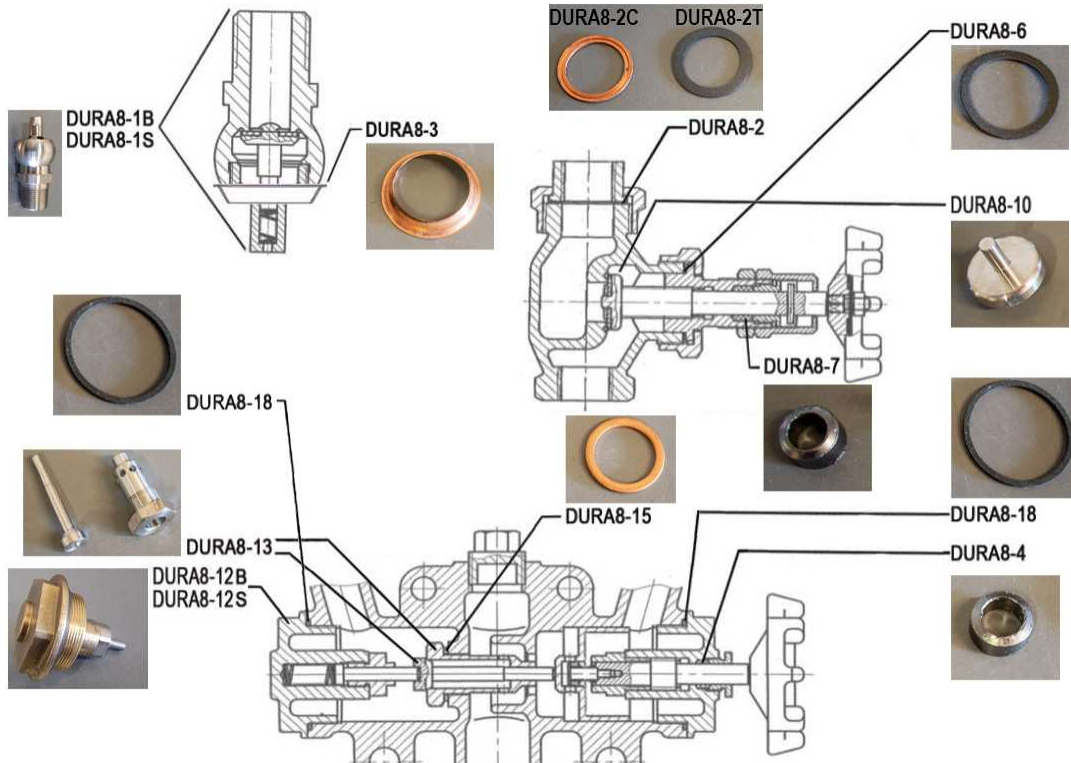

Part #	Description
DURA8-1B	Check valve assembly. Includes check valve poppet, spring, and copper connection gasket. Bronze.
DURA8-1S	Check valve assembly. Includes check valve poppet, spring, and copper connection gasket. Stainless Steel.
DURA8-2-T	Globe valve connection gasket. Teflon. Cold water.
DURA8-2-C	Globe valve connection gasket. Copper. Steam.
DURA8-3	Check valve connection gasket. Copper.
DURA8-4	Temperature control stem guide. Teflon filling.
DURA8-6	Globe valve stem guide nut gasket. Teflon.
DURA8-7	Globe valve stem guide Teflon filling.
DURA8-10S	Globe valve poppet. Stainless steel.
DURA8-12B	Steam chamber cover plate assembly. Bronze
DURA8-12S	Steam chamber cover plate assembly. Stainless Steel.
DURA8-13	Steam poppet and poppet seat. Stainless steel
DURA8-15	Steam poppet seat copper gasket.
DURA8-18	Temperature control chamber plate gasket. Teflon.
HAND WHEEL-(BLUE)	Globe valve hand wheel (Blue)
HAND WHEEL-(RED)	Globe valve hand wheel (Red)
GV-STEAM	Globe valve for steam and cold water mixing unit. Bronze. Steam side.
GV-STEAM-SS	Globe valve for steam and cold water mixing unit. Stainless steel. Steam side.
GV-WATER	Globe valve for steam and cold water mixing unit. Bronze. Water side.
GV-WATER-SS	Globe valve for steam and cold water mixing unit. Stainless steel. Water side.

SuperKlean Washdown Products, 1 Edwards Court, Suite 101, Burlingame, CA 94010, USA

Tel: (650) 375-7001 Fax: (650) 375-7010

www.superklean.com

# SuperKlean

## Environmentally Exceptional Washdown Products

(Charts below are for reference purposes only)  
(Saturated Steam Only)

For example, provided you have the following:

1. Inlet water: 60 PSI @ 50°F (10°C)
2. Inlet steam: 75 PSI
3. Desired output: 12 GPM @ 105°F (41°C)

Temperature rise in F° should be converted to temperature rise in C° using the following formula:

$$\text{Temp. Rise C}^\circ = (\text{Temp. High F}^\circ - \text{Temp. Low F}^\circ) / 1.8$$

Temperature Rise = 105-50 = 55°F. By examining the table with 55°F temperature rise, we discover that a water output of 12.1 GPM can be achieved with 60 PSI water and 75 PSI steam. This means that one Duramix 8000 unit will be able to produce 12.1 GPM@105°F at the outlet, thus satisfying the requirements. Please note that in some cases it will be necessary to install multiple Duramix 8000 units if the desired outflow is higher than what is indicated on this chart.

0°F (0°C) Temperature Rise Flow Rate: (30 PSI water pressure) 13.1 GPM, (45PSI water pressure) 13.3 GPM, (60 PSI water pressure) 13.6 GPM, (75 PSI water pressure) 13.8 GPM

55°F (31°C) Temperature Rise  
(Inlet Water Temperature + 55°F (31°C) Temperature Rise = Outlet Temperature Output)

STEAM \ WATER	45 PSI (3 Bar)	75 PSI (5 Bar)	100 PSI (7 Bar)	125 PSI (9 Bar)	150 PSI (10 Bar)
30 PSI (2 Bar)	10.0 gal/min 37.9 l/min	11.8 gal/min 44.7 l/min	13.0 gal/min 49.2 l/min	14.1 gal/min 53.4 l/min	15.2 gal/min 57.5 l/min
45 PSI (3 Bar)	10.0 gal/min 37.9 l/min	12.0 gal/min 45.4 l/min	13.2 gal/min 50.0 l/min	14.2 gal/min 53.8 l/min	15.3 gal/min 57.9 l/min
60 PSI (4 Bar)	10.2 gal/min 38.6 l/min	12.1 gal/min 45.8 l/min	14.0 gal/min 53.0 l/min	14.3 gal/min 54.1 l/min	15.6 gal/min 59.1 l/min
75 PSI (5 Bar)	10.3 gal/min 39.0 l/min	12.3 gal/min 46.6 l/min	14.2 gal/min 54.9 l/min	14.5 gal/min 54.9 l/min	15.7 gal/min 59.4 l/min

100°F (56°C) Temperature Rise  
(Inlet Water Temperature + 100°F (56°C) Temperature Rise = Outlet Temperature Output)

STEAM \ WATER	45 PSI (3 Bar)	75 PSI (5 Bar)	100 PSI (7 Bar)	125 PSI (9 Bar)	150 PSI (10 Bar)
30 PSI (2 Bar)	6.5 gal/min 24.6 l/min	8.0 gal/min 30.3 l/min	8.5 gal/min 32.2 l/min	9.4 gal/min 35.6 l/min	10.2 gal/min 38.6 l/min
45 PSI (3 Bar)	6.5 gal/min 24.6 l/min	8.2 gal/min 31.0 l/min	9.0 gal/min 34.1 l/min	9.6 gal/min 36.3 l/min	10.5 gal/min 39.7 l/min
60 PSI (4 Bar)	6.8 gal/min 25.7 l/min	8.2 gal/min 31.0 l/min	9.9 gal/min 37.5 l/min	10.0 gal/min 37.9 l/min	10.7 gal/min 40.5 l/min
75 PSI (5 Bar)	6.9 gal/min 26.1 l/min	8.3 gal/min 31.4 l/min	10.1 gal/min 38.2 l/min	10.3 gal/min 39.0 l/min	10.9 gal/min 41.3 l/min

135°F (75°C) Temperature Rise  
(Inlet Water Temperature + 135°F (75°C) Temperature Rise = Outlet Temperature Output)

STEAM \ WATER	45 PSI (3 Bar)	75 PSI (5 Bar)	100 PSI (7 Bar)	125 PSI (9 Bar)	150 PSI (10 Bar)
30 PSI (2 Bar)	4.6 gal/min 17.4 l/min	6.7 gal/min 25.4 l/min	7.2 gal/min 27.3 l/min	8.3 gal/min 31.4 l/min	9.5 gal/min 36.0 l/min
45 PSI (3 Bar)	4.8 gal/min 18.2 l/min	7.0 gal/min 26.5 l/min	7.6 gal/min 28.8 l/min	8.5 gal/min 32.2 l/min	9.7 gal/min 36.7 l/min
60 PSI (4 Bar)	4.8 gal/min 18.2 l/min	7.2 gal/min 27.3 l/min	7.8 gal/min 29.5 l/min	8.6 gal/min 32.6 l/min	9.8 gal/min 37.1 l/min
75 PSI (5 Bar)	4.9 gal/min 18.5 l/min	7.3 gal/min 27.6 l/min	8.0 gal/min 30.3 l/min	8.9 gal/min 33.7 l/min	10.1 gal/min 39.4 l/min